

## 960~1000nm High Power Optical Isolator

### FEATURES

- High Isolation
- Low Insertion Loss
- Epoxy-Free Optical Path
- High Reliability and Stability
- Low Profile Packaging

### APPLICATIONS

- Broadband Systems
- Optical Amplifying Systems
- Telecommunication Networks
- Metro Networks
- CATV Networks

### SPECIFICATIONS

Parameter	Unit	Single Stage	Dual Stage D Type	Dual Stage L Type
Center Wavelength ( $\lambda_c$ )	nm	975, 980, 990, 1000		
Operating Wavelength Range	nm	+/-10		
Peak Isolation (Typ.)	dB	28	46	
Min. Isolation (23°C)	dB	22	40	
Typical Insertion Loss ( $\lambda_c$ , 23°C)	dB	0.9	1.1	1.3
Max. Insertion Loss ( $\lambda_c$ , 23°C)	dB	1.5	1.8	
Optical Return Loss (Input/Output)	dB	50/50		
Max. Polarization Dependent Loss	dB	0.15		
Configuration	-	Standard: 2-Port; Y Type: 3-Port, Backward Power Guide Out		
Fiber Type	Input&Output	-	HI1060 Fiber or 10/125um SC Fiber (E) 10/125um DC Fiber (O), 15/130um DC Fiber (W) 20/130um DC Fiber (Q) or 25/250um DC Fiber (R)	
	3 <sup>rd</sup> Port (Y Type)	-	Same Fiber or 105/125um MM Fiber	
Fiber Tensile Load	N	5		
Max. Optical Power (CW)	W	0.3, 0.5, 1, 2, 3, 5, 10, 15, 20, 30, 50, 60, 80, 100		
Max. Backward Average Power	W	0.3, 0.5, 1, 2, 3, 5, 10		
Operating Temperature	°C	0~50		
Storage Temperature	°C	-20~75		

**Note:** 1. Specifications are for device without connectors; Specifications may change without notice.

2. To add connectors, IL is 0.5dB higher, RL is 5dB lower.

3. Only guarantee 1W continuous wave (CW) power thru testing for connectors added.

4. Suggest to use Y type for >20W Optical Power or continuous backward power of  $\geq 500$ mW.

5. Devices for higher optical power or with other type fiber or consigned fiber are also available; Devices can only work in the core of Double Cladding (DC) Fiber, Cladding Power must be stripped before connecting the device.

6. Package dimensions may be different for different fiber type, configuration and optical power.

### PACKAGE DIMENSION

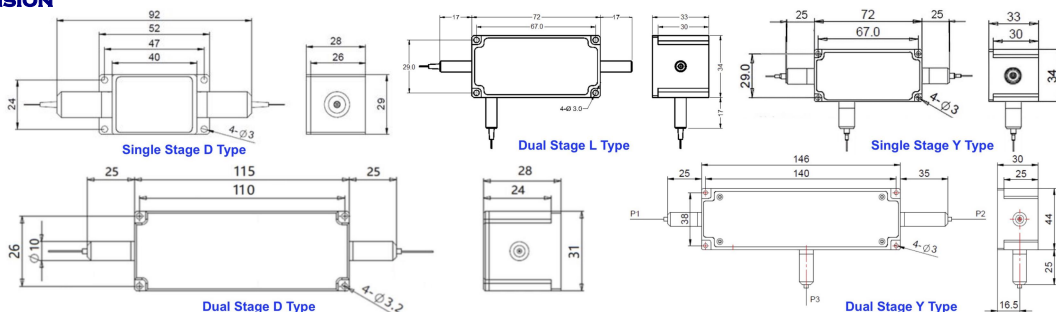

### ORDERING INFORMATION (PN)

FISO-NNN	- (C)	(C)	-HP NN	- (NN)	- (C)	C	NN	-CC/CC
Center Wavelength	Stage	3 <sup>rd</sup> Port Fiber	Optical Power	Backward Power	Fiber Type	Fiber Sleeve	Fiber Length	Connector Type
975~975nm	D=D Type	Y= Same Fiber	1=1W	05=500mW	E=10/125um SC Fiber	B= Bare Fiber	05=0.5m	N=Without Connector
980~980nm	L=L Type	A=105/125um Fiber	5=5W	1=1W	Q=20/130um DC Fiber	L= Loose Tube	10=1.0m	FC/APC=FC/APC Connector
990~990nm	Blank for Single	Blank for Standard	10=10W	10=10W	R=25/250um DC Fiber	2= 2mm Cable	15=1.5m	LC/PC=LC/PC Connector
1000~1000nm			100=100W	Blank for 300mW	Blank for HI1060 Fiber	3= 3mm Cable	20=2.0m	SC/UPC=SC/UPC Connector

